



**VACUUM  
TECHNOLOGY**



**OPERATING AND MAINTENANCE  
INSTRUCTIONS**

*(Translation of the original instructions)*

**VACUUM PUMPS WITH RECIRCULATING  
LUBRICATION SYSTEM**

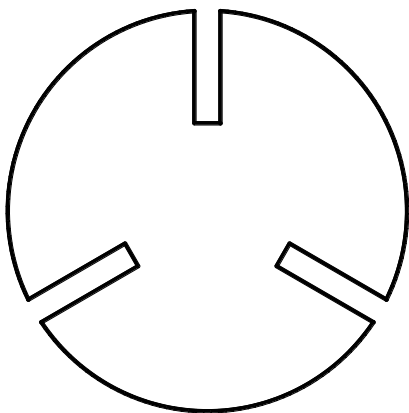

**LC 25  
LC 40  
LC 60  
LC 106  
LC 151  
LC 106 Kzero  
LC 151 Kzero  
LC 205  
LC 305  
LC 205 Kzero  
LC 305 Kzero  
LC 205HV  
LC 305HV  
RC 50M**

## INDEX

<b>1</b>	<b>INTRODUCTION</b>	<b>2</b>
1.1	GENERAL INFORMATION	2
1.2	MANUFACTURER INFORMATION	2
1.3	METHOD OF CONSULTATION	2
1.4	PERSONNEL QUALIFICATIONS	2
1.5	PERSONAL PROTECTION EQUIPMENT	3
1.6	INFORMATION PLATE	3
<b>2</b>	<b>SAFETY</b>	<b>3</b>
2.1	GENERAL WARNINGS	3
2.2	RESIDUAL RISKS	3
2.3	PICTOGRAMS	4
<b>3</b>	<b>PUMP DESCRIPTION</b>	<b>5</b>
3.1	INTENDED USE AND CONTRAINDICATIONS	5
3.1.1	INTENDED USE	5
3.1.2	CONTRAINDICATIONS	5
3.2	FKM VERSION	5
3.3	KZERO MODEL	5
3.4	DIMENSIONS AND CHARACTERISTICS	6
3.4.1	Model: LC 25	6
3.4.2	Model: LC 40 – LC 60	7
3.4.3	Model: LC 106 – LC 151	8
3.4.4	Model: LC 106 Kzero – LC 151 Kzero	9
3.4.5	Model: LC 205 – LC 305	10
3.4.6	Model: LC 205 Kzero – LC 305 Kzero	11
3.4.7	Model: LC 205HV – LC 305HV	12
3.4.8	Model: RC 50M	13
3.5	NOISE EMISSION	14
<b>4</b>	<b>INSTALLATION</b>	<b>14</b>
4.1	RECEIPT AND CONTENT VERIFICATION	14
4.2	PACKAGING	14
4.3	TRANSPORT AND HANDLING	14
4.4	STORAGE	14
4.5	ENVIRONMENTAL CONDITIONS	15
4.6	PUMP INSTALLATION	15
4.7	MOTOR INSTALLATION	15
4.8	USER SYSTEM	15
4.9	CONNECTION	16
4.9.1	INTAKE AND OUTLET CONNECTIONS	16
4.9.2	WIRING	16
4.9.3	ELECTRICAL OIL LEVEL GAUGE (OPTIONAL)	16
<b>5</b>	<b>OPERATING INSTRUCTIONS</b>	<b>17</b>
5.1	OPERATION	17
5.1.1	FILLING THE OIL TANK	17
5.1.2	START-UP	17
5.1.3	STOP	17
5.1.4	PUMPING WATER VAPOUR	18
<b>6</b>	<b>MAINTENANCE</b>	<b>18</b>
6.1	GENERAL WARNINGS	18
6.2	MAINTENANCE TABLE	19
6.2.1	CHECK OIL LEVEL	19
6.2.2	CHANGE OIL	19
6.2.3	CLEAN RADIATOR, MOTOR FAN GUARD AND CLEAN THE PUMP	19
6.2.4	CHANGE THE AIR EXHAUST FILTER	19
6.2.5	CHANGE THE OIL FILTER (ONLY WHERE PRESENT)	20
6.2.6	CHANGE VANES	20
6.3	SPARE PARTS	20
<b>7</b>	<b>HOW TO RETURN THE PUMP</b>	<b>21</b>
<b>8</b>	<b>DISMANTLING</b>	<b>21</b>
<b>9</b>	<b>TROUBLESHOOTING</b>	<b>22</b>

# 1 INTRODUCTION

## 1.1 GENERAL INFORMATION

This manual is meant to provide you with important information for the safety of persons involved in pump use and maintenance.

This manual, originally written in ITALIAN, is an integral part of the pump and must be preserved with care for the life of the pump itself. In the event of sale, lease or loaned use of the pump, it must be delivered to the new user along with EC declaration of conformity.

Carrying out any operations on the pump before reading and fully understanding all instructions in this manual is prohibited.

The images contained in this document are examples only and are not binding for the Manufacturer. The Manufacturer reserves the right to make changes to components, product improvement parts and any other without updating this manual, if said components or parts do not alter pump operation and safety.

## 1.2 MANUFACTURER INFORMATION

### **D.V.P. Vacuum Technology s.p.a.**

Via Rubizzano, 627

40018 - S. Pietro in Casale (BO) - ITALY

Tel. +39 051 188 971 11

Fax +39 051 188 971 70

e-mail: [info@dvp.it](mailto:info@dvp.it)

web site: <http://www.dvppumps.com>

Please always include the following information in all communications regarding the pump:

- pump model and serial number
- year of manufacture
- date of purchase
- detail information regarding problems verified

## 1.3 METHOD OF CONSULTATION

For improved understanding of the information provided in this manual, warnings or instructions considered critical or hazardous are marked with the following symbols:



### **HAZARD**

Failure to comply with these instructions may cause hazards to persons.



### **WARNING**

Failure to comply with these instructions may cause damage to the pump.

## 1.4 PERSONNEL QUALIFICATIONS



**DVP products covered by this manual are intended for PROFESSIONAL use only.**

To ensure that all operations performed on the pump are carried out safely, operators must have the qualifications and requirements to carry out its operations.

Operators are classified as follows:



### **FIRST LEVEL OPERATOR:**

Unqualified personnel, having no specific skills, able to perform simple tasks only.



### **MECHANICAL MAINTENANCE OPERATOR:**

Technician qualified to work on mechanical parts to carry out any necessary adjustments, maintenance or repairs. Not qualified to work on electrical systems in the presence of voltage.



### **ELECTRICAL MAINTENANCE OPERATOR:**

Technician in charge of all operations of an electrical nature. Can operate in the presence of voltage inside cabinets and connector boxes.

### 1.5 PERSONAL PROTECTION EQUIPMENT

This manual assumes that the pump has been installed in workplaces, which comply with all mandatory safety requirements; in particular, it is mandatory that personnel are equipped with personal protective equipment in relation to the activities that must be performed.

### 1.6 INFORMATION PLATE

All pumps are equipped with an identification plate that contains the manufacturer's name, address, CE marking and technical data of the pump itself.

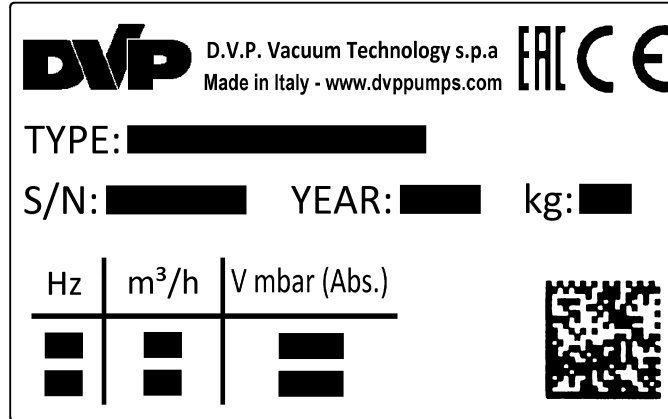

**WARNING**

Removing or tampering with the identification plate is strictly prohibited.

## 2 SAFETY

### 2.1 GENERAL WARNINGS

It is important to read this manual before performing any operation on the pump. Compliance with the safety standards of the country in which the pump is installed and requirements of qualified personnel for various maintenance, use, installation, etc. are recommended throughout the life of the pump.

The main rules of conduct to be observed for operation at a suitable level of security are the following:

- Installation, operation, maintenance, etc. operations should always be performed by qualified, trained personnel.
- Without exception, always wear necessary personal protective equipment.
- Always perform all cleaning, adjustment and maintenance operations with all power equipment cut off.
- Do not direct water jets toward electrical parts, even if they are protected by enclosures.
- Do not smoke during work or maintenance, especially where solvents or flammable materials are being used.
- Do not damage symbol plaques or pictograms on the pump. If they should accidentally become damaged, immediately replace them with other identification plaques.

D.V.P. Vacuum Technology s.p.a. disclaims any liability for damage to persons or property resulting from improper use of the pump, from tampering with its safety apparatus or failure to observe operational safety standards.

### 2.2 RESIDUAL RISKS

**HAZARD**



**This pump has been designed to minimise residual risks to personnel. We urge you, however, to take the utmost care and attention in carrying out maintenance operations. The confidence gained with frequent contact with the pump too often leads users to forget or underestimate risks.**

**High temperature hazard**

Pump surfaces can exceed a temperature of 70°C. Install the pump in a protected area that is accessible only by authorised personnel and only perform operations when the pump is stopped and cooled.

**Hazard generated by low pressure**

Avoid contact with pump intake attachment during operation. Introduce air into the suction circuit before any intervention. Contact with low pressure points can cause accidents.

**Hazard generated by pressure**

The pump tank is pressurised. Do not open and do not leave oil filler or drain plugs open during operation.

**Danger from the emission of harmful substances**

Pump outlet air contains traces of oil mist. Ensure compatibility with the working environment. Faults or wearing of seals may cause oil lubricant leaks. Avoid dispersion in soil and pollution of other materials. Whenever air containing hazardous substances are sucked in (i.e. biological or microbiological agents), use abatement systems placed before the vacuum pump. Used oil must be disposed of according to applicable regulations in the country of pump use.

**Electrical hazard**

Electrical equipment in the pump includes live parts which, upon contact, can cause serious damage to persons and property. Any kind of intervention on the electrical system must be performed by qualified personnel.

**Fire hazard**

Use of the pump for any uses not provided for or prohibited by this manual as well as a lack of proper maintenance can cause malfunction with a risk of overheating and fire. In case of fire, do not use water to extinguish the flames, but use dry chemical or CO<sub>2</sub> or other means compatible with the presence of electrical equipment and lubricants.

**Slip and fall hazards**

The “L” series vacuum pumps use lubricant to operate. A simple maintenance or improper use not complying with the instructions included in this manual can damage the gaskets and/or seals and cause the lubricant to spill on the floor constituting slip and/or fall hazards for personnel.

**Entanglement hazard**

There is a permanent impending hazard of entangling or entrapping hair and clothing in the cooler fan inside the guard near the fan casing on the electric motor. Tie long hair up and do not wear baggy clothing, long laces or other items that could get caught up.

**Part projection hazard**

Install the pump in order to avoid those in charge of works being directly hit by parts or bits of parts flying through the fan cover casing due to the cooling fan breaking.

**2.3 PICTOGRAMS**

Pictographs with the warning symbols and safety symbols for operators have been applied to the pump. Read carefully and take note of the symbols and their messages before using the pump.

**ELECTRICAL HAZARD**

**The pump is near electrical connections (protected) but where accidental contact can cause electric shock and death.**

**HOT SURFACE HAZARD**

**The pump is close to surfaces with temperatures exceeding 70°C which may lead to burns of medium severity.**

D.V.P. Vacuum Technology s.p.a. disclaims any liability for damage to persons or property due to non-compliance with instructions indicated in pictograms or their improper preservation.

## 3 PUMP DESCRIPTION

### 3.1 INTENDED USE AND CONTRAINDICATIONS

#### 3.1.1 INTENDED USE



DVP products covered by this manual are intended for **PROFESSIONAL** use only.

The pumps described in this manual are oil recirculating rotary vane pumps.

These vacuum pumps have been specifically designed to work with clean air, inert gas or small amounts of water vapour, having a temperature between 12 and 40 °C at the intake.

Any other use is prohibited. The Manufacturer is not liable for any damage to persons and/or property caused by improper use or not allowed use of the pump.

#### 3.1.2 CONTRAINDICATIONS



**Any use other than that for which the pump was constructed is to be considered an abnormal condition and therefore can cause damage to the pump and pose a serious danger to the operator.**

Below is a series of operations involving improper use of the pump, which are not permitted under any circumstances.

- Do not use the pump in an explosive or aggressive atmosphere or in an atmosphere with a high concentration of dust or oily substances in the air and do not use the pump to pump explosive, flammable or corrosive gases or gas that form particles. Using the pump in these atmospheres and with these types of gases can cause injury, explosion, fire or serious damage to the pump.
- Do not use non-original spare parts or parts not provided by the manufacturer.
- Do not use the unit to pump solid materials, chemicals, powders, solvents or other substances differing from those permitted. These types of materials may damage the unit, degrade its performance or reduce its life.
- do not expose the pump to rain, steam or excessive humidity.
- Do not place or store near in the proximity of flammable or combustible materials or substances.
- Do not use the pump as a compressor.

### 3.2 FKM VERSION

This version of the pump is equipped with special technical devices, such FKM seals that allow for use even in the presence of some aggressive gases.



#### **WARNING**

**Contact the seller to make sure that the pump is suitable for use with a given aggressive gas.**

### 3.3 Kzero MODEL

This type of pump has been designed for particularly demanding applications. For more information, contact the Manufacturer.

## 3.4 DIMENSIONS AND CHARACTERISTICS

### 3.4.1 Model: LC 25

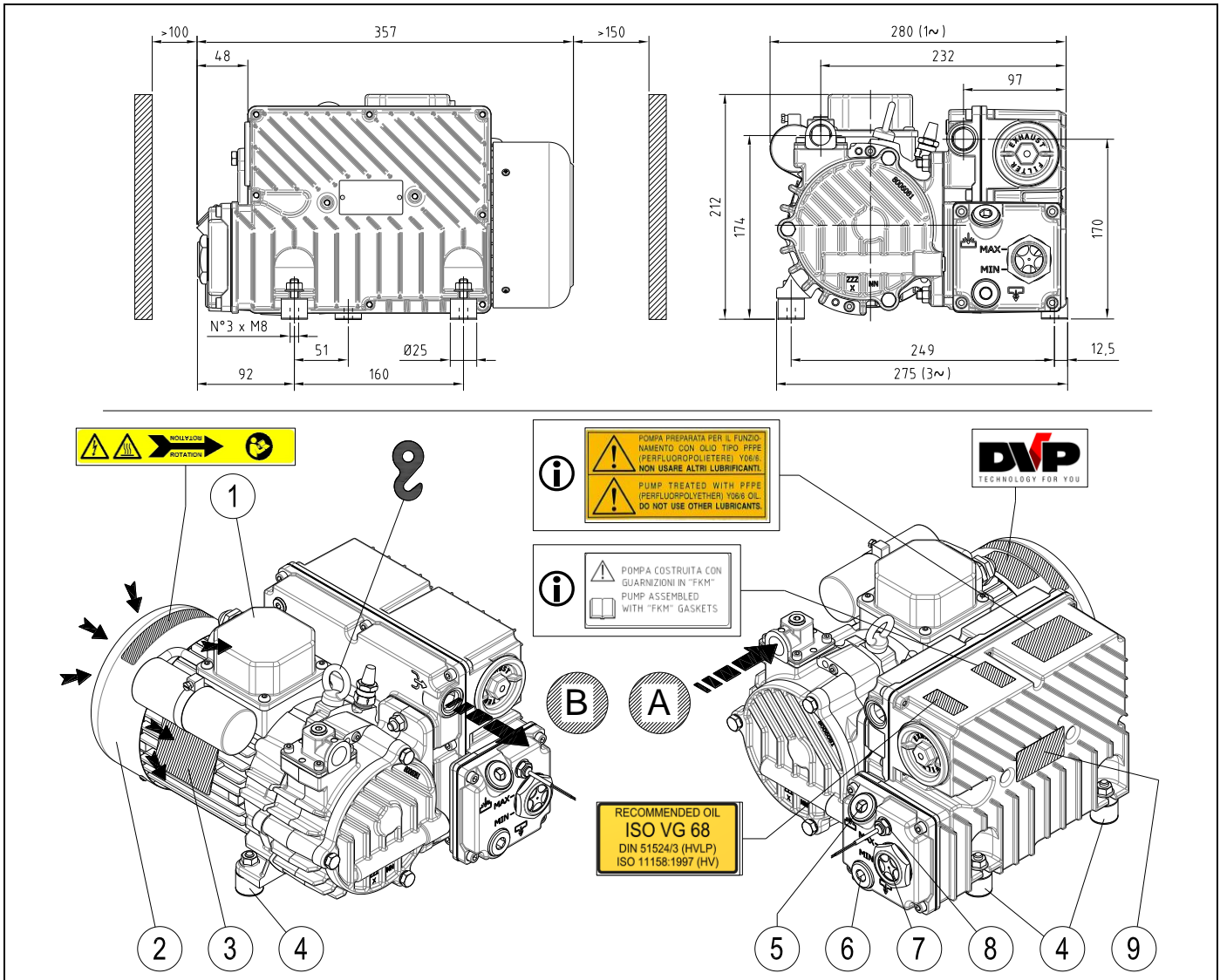

<b>A</b>	Intake
<b>B</b>	Air outlet
<b>1</b>	Terminal board
<b>2</b>	Motor fan guard

<b>3</b>	Motor rating plate
<b>4</b>	Attachment point
<b>5</b>	Oil filler plug
<b>6</b>	Oil drain plug

<b>7</b>	Oil sight glass
<b>8</b>	Level switch (optional)
<b>9</b>	Information plate
<b>i</b>	Only present on special versions

### TECHNICAL SPECIFICATIONS

	LC 25		
	50 Hz	60 Hz	
Inlet capacity	m <sup>3</sup> /h	25	29
Final pressure (Abs.)	mbar - hPa	0,5	
Max inlet pressure for water vapour	mbar - hPa	40	
Max water vapour pumping rate	Kg/h	0,7	
Motor power	kW (1~ / 3~)	0,75 / 0,75	0,9 / 0,9
Nominal r.p.m.	n/min	1400	1700
Noise level (UNI EN ISO 2151) (K 3dB)	dB(A)	57	59
Weight	kg (1~ / 3~)	26 / 25	
Type of oil	cod. DVP	BV68 (SW60)	
Oil quantity	Min÷Max dm <sup>3</sup>	0,7 ÷ 1	
Pump Intake / Outlet	"G"	1/2 / 1/2	
Continuous-duty working range (Abs.)	mbar - hPa	400 ÷ 0,5	
Operating temperature (room temp. 20°C)	°C	80 ÷ 85	85 ÷ 90
Required room temp. for place of installation	°C	12 ÷ 40	
Ambient temperature for storage/transport	°C	-20 ÷ 50	
MAX humidity / altitude		80% / 1000m s.l.m. <sup>(1)</sup>	

(1) Please contact the Manufacturer if environmental conditions are different from those prescribed.



## 3.4.2 Model: LC 40 – LC 60

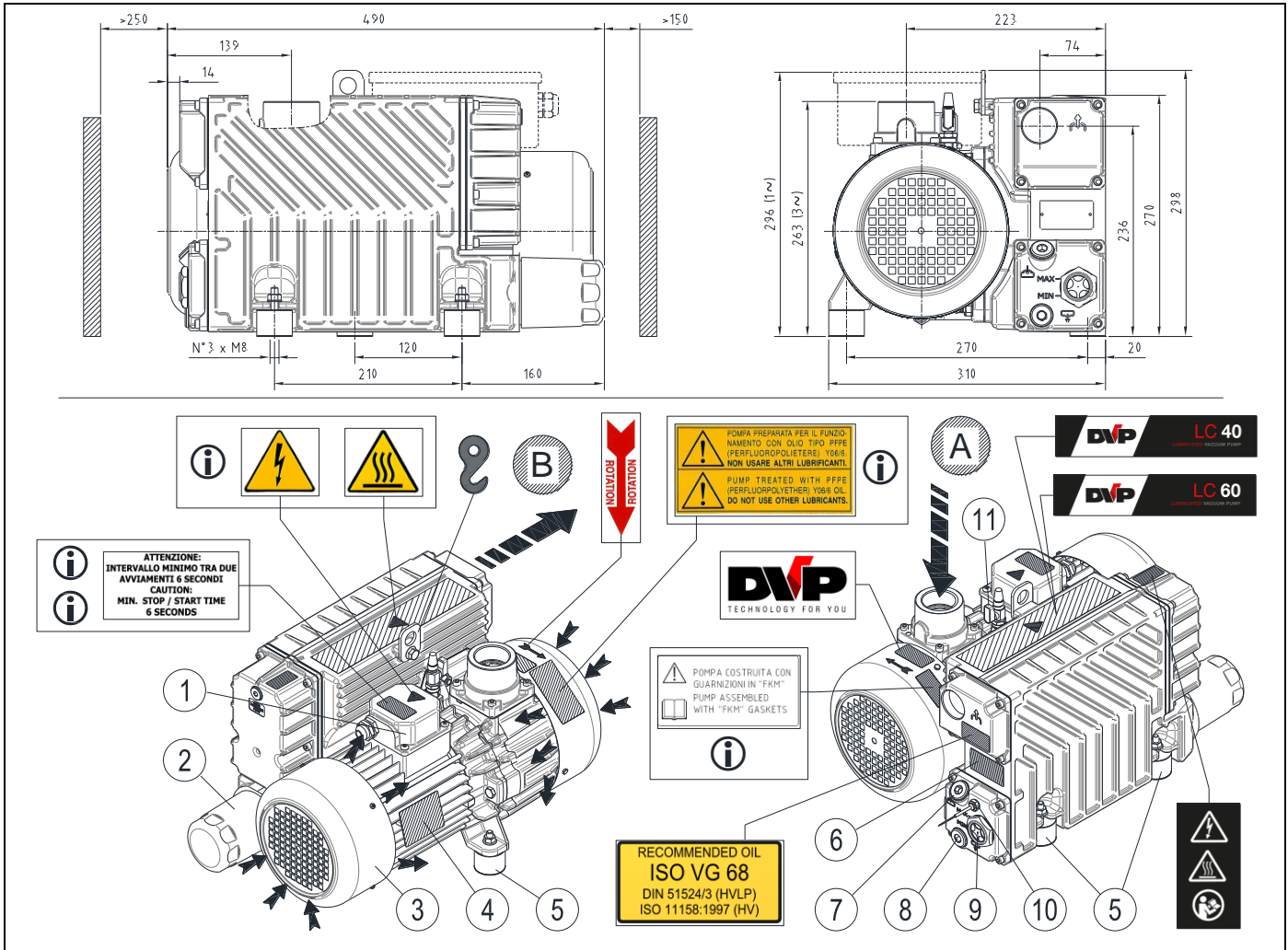

<b>A</b>	Intake
<b>B</b>	Air outlet
<b>1</b>	Terminal board
<b>2</b>	Oil filter
<b>3</b>	Motor fan guard

<b>4</b>	Motor rating plate
<b>5</b>	Attachment point
<b>6</b>	Information plate
<b>7</b>	Oil filler plug
<b>8</b>	Oil drain plug

<b>9</b>	Oil sight glass
<b>10</b>	Level switch (optional)
<b>11</b>	Gas Ballast ON/OFF
<b>ⓘ</b>	Only present on special versions
<b>ⓘ ⓘ</b>	Only present on 1~ versions

### TECHNICAL SPECIFICATIONS

		LC 40		LC 60	
		50 Hz	60 Hz	50 Hz	60 Hz
Inlet capacity	m <sup>3</sup> /h	40	48	60	72
Final pressure (Abs.)	mbar - hPa	0,1 <sup>(2)</sup>			
Max inlet pressure for water vapour	mbar - hPa	14 <sup>(3)</sup>		14 <sup>(3)</sup>	
Max water vapour pumping rate	Kg/h	0,5 <sup>(3)</sup>		0,7 <sup>(3)</sup>	
Motor power	kW (1~ / 3~)	1,1 / 1,1	1,35 / 1,35	1,5 / 1,5	1,8 / 1,8
Nominal r.p.m.	n/min	1400	1700	1400	1700
Noise level (UNI EN ISO 2151) (K 3dB)	dB(A)	64	66	66	68
Weight	kg (1~ / 3~)	46,5 / 42		46 / 44	
Type of oil	cod. DVP	BV68 (SW60)			
Oil quantity	Min÷Max dm <sup>3</sup>	1 ÷ 1,5			
Pump Intake / Outlet	"G	1-1/2 / 1-1/4			
Continuous-duty working range (Abs.)	mbar - hPa	400 ÷ 0,1			
Operating temperature (room temp. 20°C)	°C	65 ÷ 70	70 ÷ 75	70 ÷ 75	75 ÷ 80
Required room temp. for place of installation	°C	12 ÷ 40			
Ambient temperature for storage/transport	°C	-20 ÷ 50			
MAX humidity / altitude		80% / 1000m s.l.m. <sup>(1)</sup>			

(1) Please contact the Manufacturer if environmental conditions are different from those prescribed.

(2) With ballast closed.

(3) With open Gas Ballast.



### 3.4.3 Model: LC 106 – LC 151

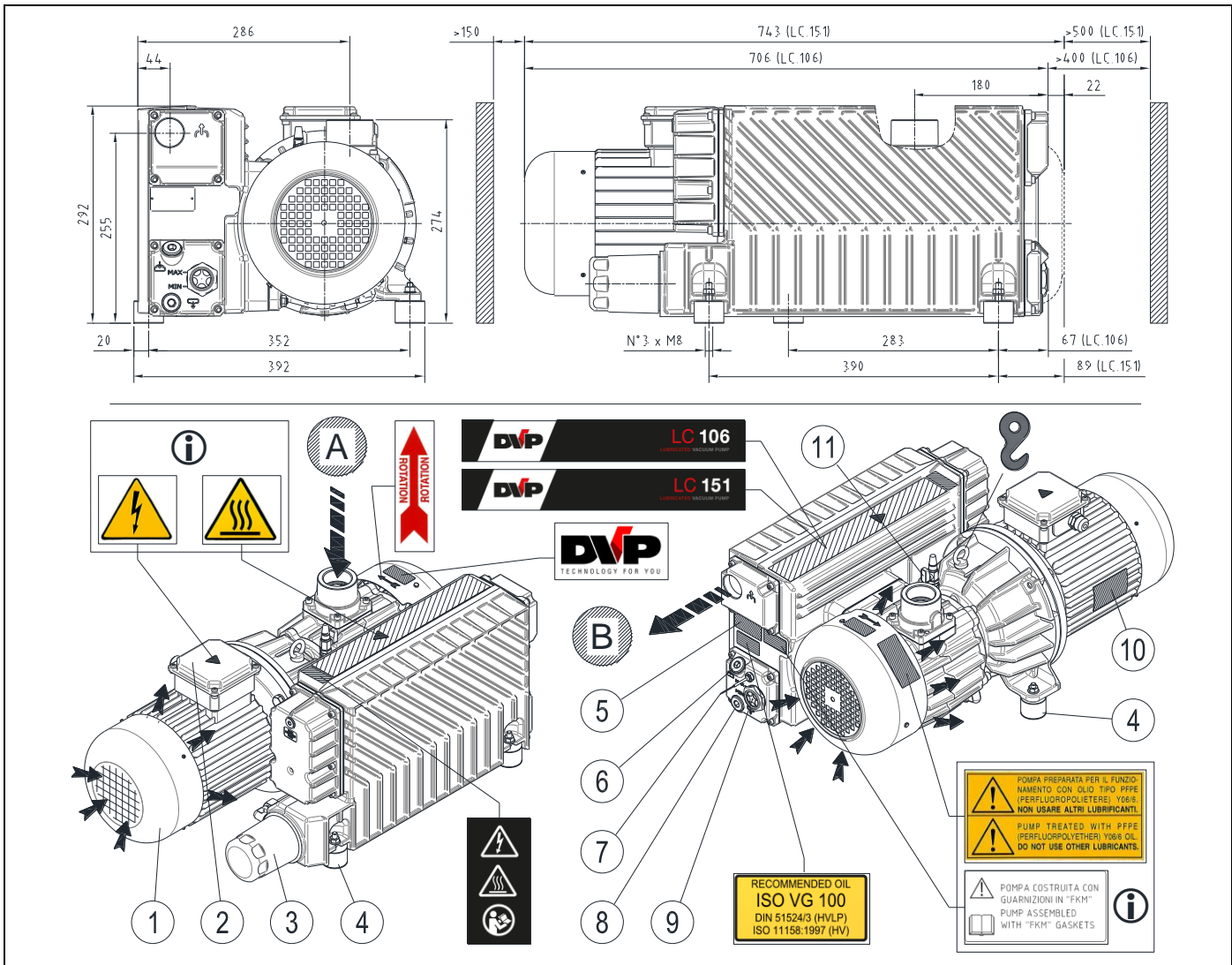

<b>A</b>	Intake
<b>B</b>	Air outlet
<b>1</b>	Motor fan guard
<b>2</b>	Terminal board
<b>3</b>	Oil filter

<b>4</b>	Attachment point
<b>5</b>	Information plate
<b>6</b>	Oil filler plug
<b>7</b>	Level switch (optional)
<b>8</b>	Oil drain plug

<b>9</b>	Oil sight glass
<b>10</b>	Motor rating plate
<b>11</b>	Gas Ballast ON/OFF
<b>i</b>	Only present on special versions

### TECHNICAL SPECIFICATIONS

		LC 106		LC 151	
		50 Hz	60 Hz	50 Hz	60 Hz
Inlet capacity	m <sup>3</sup> /h	106	127	151	181
Final pressure (Abs.)	mbar - hPa	0,1 <sup>(2)</sup>			
Max inlet pressure for water vapour	mbar - hPa	11 <sup>(3)</sup>		11 <sup>(3)</sup>	
Max water vapour pumping rate	Kg/h	1 <sup>(3)</sup>		1,4 <sup>(3)</sup>	
Motor power (IE2)	kW (3~)	2,2	3	3,3	4
Nominal r.p.m.	n/min	1400	1700	1400	1700
Noise level (UNI EN ISO 2151) (K 3dB)	dB(A)	66	68	68	70
Weight	kg (3~)	70,5		80	
Type of oil	cod. DVP	BV100 (SW100)			
Oil quantity	Min÷Max dm <sup>3</sup>	2 ÷ 3			
Pump Intake / Outlet	"G	1-1/2 / 1-1/4			
Continuous-duty working range (Abs.)	mbar - hPa	400 ÷ 0,1			
Operating temperature (room temp. 20°C)	°C	75 ÷ 80	80 ÷ 85	75 ÷ 80	80 ÷ 85
Required room temp. for place of installation	°C	12 ÷ 40			
Ambient temperature for storage/transport	°C	-20 ÷ 50			
MAX humidity / altitude		80% / 1000m s.l.m. <sup>(1)</sup>			

(1) Please contact the Manufacturer if environmental conditions are different from those prescribed.

(2) With ballast closed.

(3) With open Gas Ballast.

## 3.4.4 Model: LC 106 Kzero – LC 151 Kzero

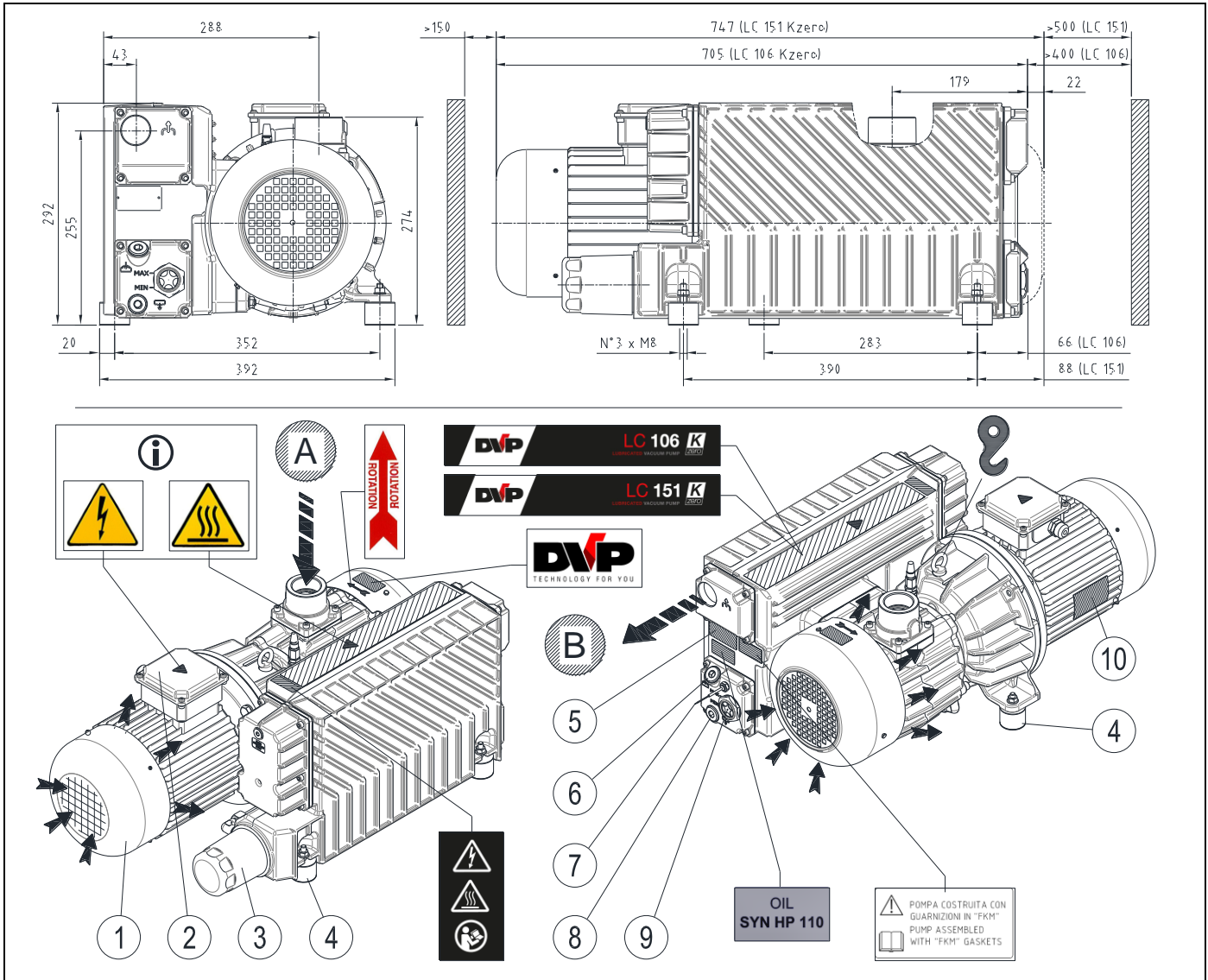

<b>A</b>	Intake
<b>B</b>	Air outlet
<b>1</b>	Motor fan guard
<b>2</b>	Terminal board
<b>3</b>	Oil filter

<b>4</b>	Attachment point
<b>5</b>	Information plate
<b>6</b>	Oil filler plug
<b>7</b>	Level switch (optional)
<b>8</b>	Oil drain plug

<b>9</b>	Oil sight glass
<b>10</b>	Motor rating plate

### TECHNICAL SPECIFICATIONS

		LC 106 Kzero		LC 151 Kzero	
		50 Hz	60 Hz	50 Hz	60 Hz
Inlet capacity	m <sup>3</sup> /h	106	127	151	181
Final pressure (Abs.)	mbar - hPa	4			
Max inlet pressure for water vapour	mbar - hPa	11		11	
Max water vapour pumping rate	Kg/h	1		1,4	
Motor power (IE2)	kW (3~)	2,2	3	3,3	4
Nominal r.p.m.	n/min	1400	1700	1400	1700
Noise level (UNI EN ISO 2151) (K 3dB)	dB(A)	67	69	69	71
Weight	kg (3~)	70,5		80	
Type of oil	cod. DVP	SYN HP 110			
Oil quantity	Min÷Max dm <sup>3</sup>	2 ÷ 3			
Pump Intake / Outlet	"G	1-1/2 / 1-1/4			
Continuous-duty working range (Abs.)	mbar - hPa	400 ÷ 4			
Operating temperature (room temp. 20°C @ 100 mbar (Abs.))	°C	95 ÷ 100	100 ÷ 105	100 ÷ 105	110 ÷ 115
Required room temp. for place of installation	°C	12 ÷ 40			
Ambient temperature for storage/transport	°C	-20 ÷ 50			
MAX humidity / altitude		80% / 1000m s.l.m. <sup>(1)</sup>			

(1) Please contact the Manufacturer if environmental conditions are different from those prescribed.

### 3.4.5 Model: LC 205 – LC 305

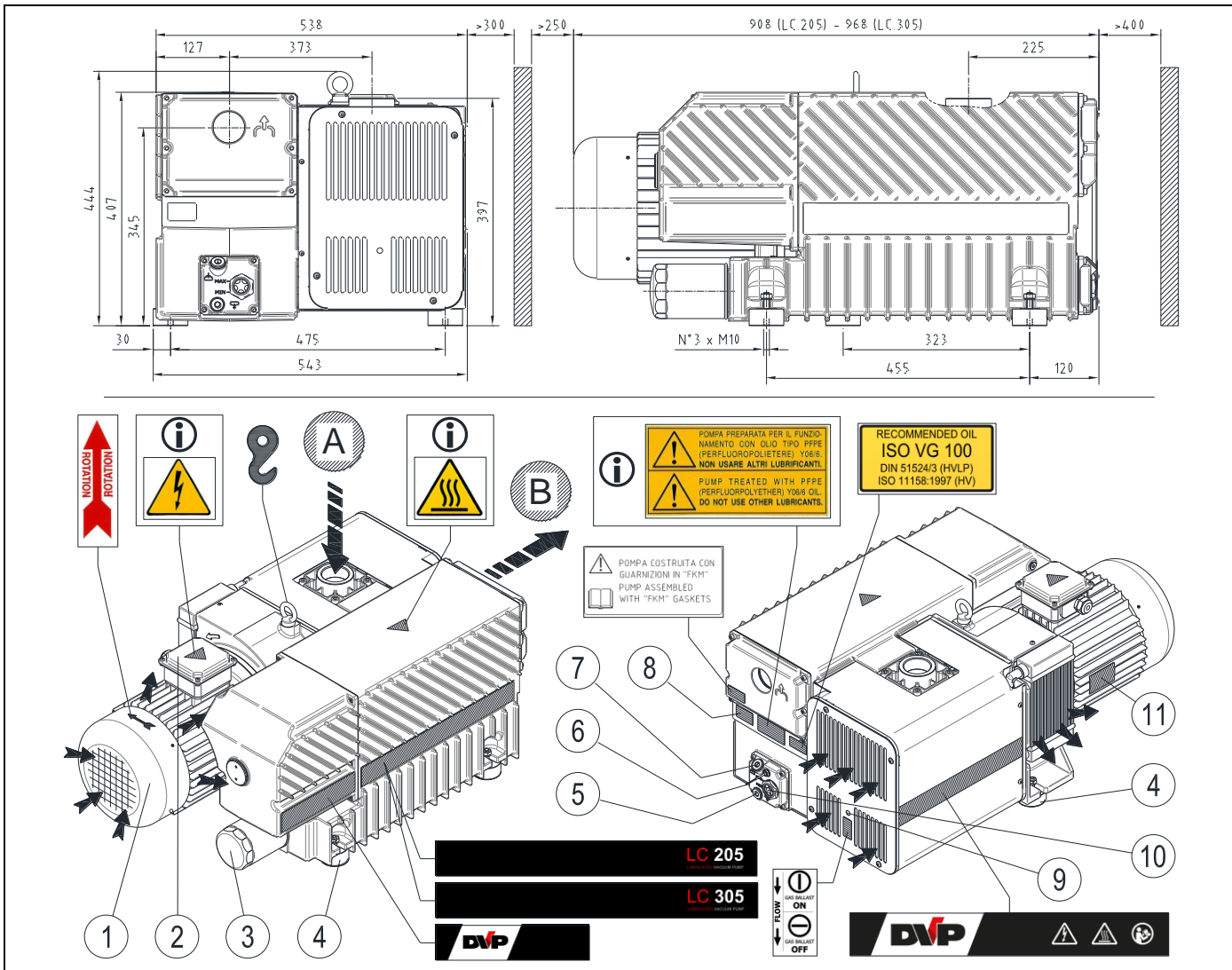

<b>A</b>	Intake
<b>B</b>	Air outlet
<b>1</b>	Motor fan guard
<b>2</b>	Terminal board
<b>3</b>	Oil filter

<b>4</b>	Attachment point
<b>5</b>	Oil drain plug
<b>6</b>	Level switch (optional)
<b>7</b>	Oil filler plug
<b>8</b>	Information plate

<b>9</b>	Gas Ballast ON/OFF
<b>10</b>	Oil sight glass
<b>11</b>	Motor rating plate
<b>i</b>	Only present on special versions

#### TECHNICAL SPECIFICATIONS

		LC 205		LC 305	
		50 Hz	60 Hz	50 Hz	60 Hz
Inlet capacity	m <sup>3</sup> /h	205	245	305	365
Final pressure (Abs.)	mbar - hPa	0,1 <sup>(2)</sup>			
Max inlet pressure for water vapour	mbar - hPa	25 <sup>(3)</sup>			
Max water vapour pumping rate	Kg/h	3,5 <sup>(3)</sup>		5 <sup>(3)</sup>	
Motor power (IE2)	kW (3~)	5,5	6,6	7,5	9
Nominal r.p.m.	n/min	1400	1700	1400	1700
Noise level (UNI EN ISO 2151) (K 3dB)	dB(A)	70	73	71	74
Weight	kg (3~)	170		180	
Type of oil	cod. DVP	BV100 (SW100)			
Oil quantity	Min÷Max dm <sup>3</sup>	4 ÷ 5			
Pump Intake / Outlet	"G	2 / 2			
Continuous-duty working range (Abs.)	mbar - hPa	400 ÷ 0,1			
Operating temperature (room temp. 20°C)	°C	70 ÷ 75	75 ÷ 80	75 ÷ 80	80 ÷ 85
Required room temp. for place of installation	°C	12 ÷ 40			
Ambient temperature for storage/transport	°C	-20 ÷ 50			
MAX humidity / altitude		80% / 1000m s.l.m. <sup>(1)</sup>			

(1) Please contact the Manufacturer if environmental conditions are different from those prescribed.  
 (2) With ballast closed.  
 (3) With open Gas Ballast.

## 3.4.6 Model: LC 205 Kzero – LC 305 Kzero

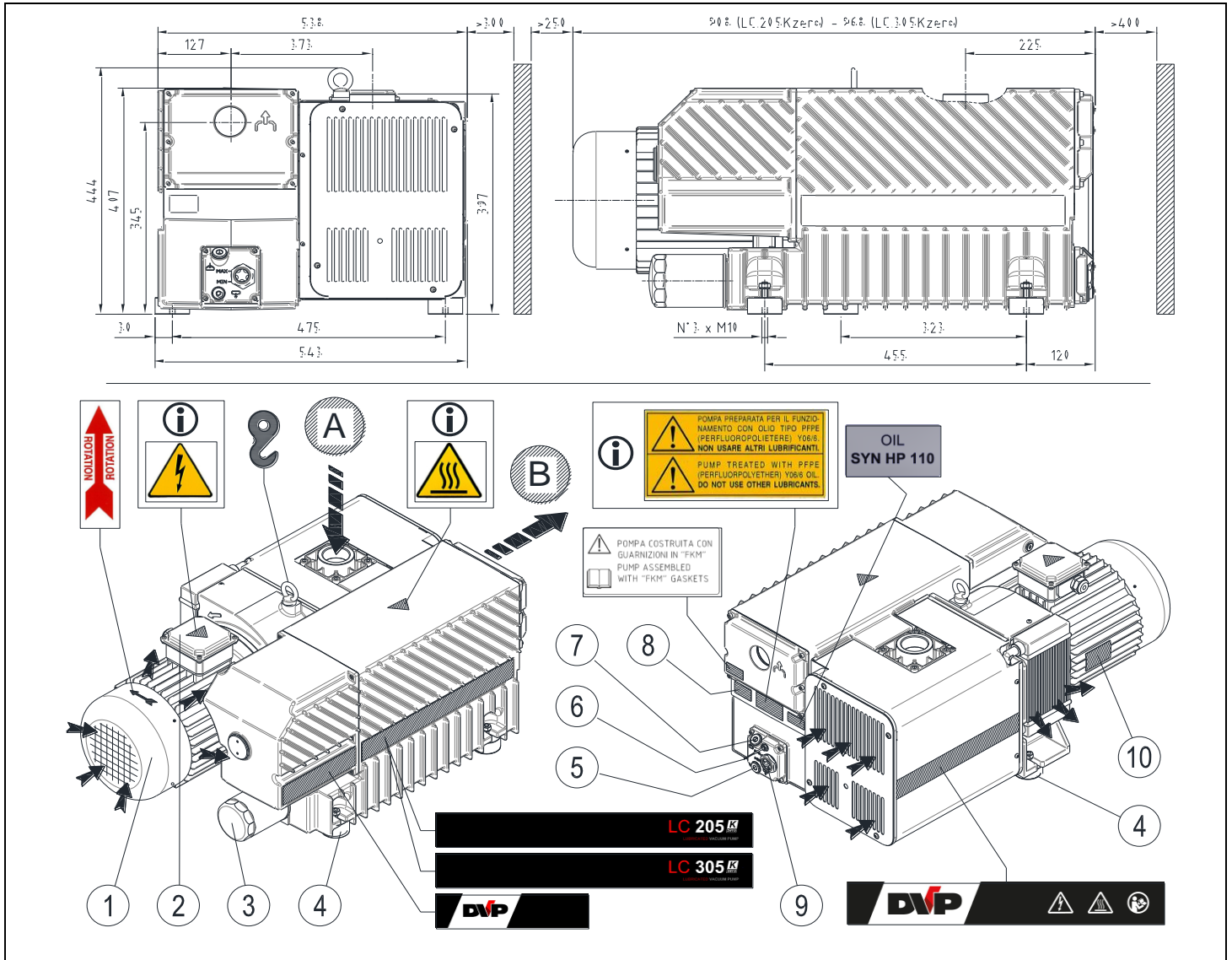

<b>A</b>	Intake
<b>B</b>	Air outlet
<b>1</b>	Motor fan guard
<b>2</b>	Terminal board
<b>3</b>	Oil filter

<b>4</b>	Attachment point
<b>5</b>	Oil drain plug
<b>6</b>	Level switch (optional)
<b>7</b>	Oil filler plug
<b>8</b>	Information plate

<b>9</b>	Oil sight glass
<b>10</b>	Motor rating plate
<b>ⓘ</b>	Only present on special versions

### TECHNICAL SPECIFICATIONS

	LC 205 Kzero		LC 305 Kzero	
	50 Hz	60 Hz	50 Hz	60 Hz
Inlet capacity	m <sup>3</sup> /h		205	365
Final pressure (Abs.)	mbar - hPa		0,3	
Max inlet pressure for water vapour	mbar - hPa		25	
Max water vapour pumping rate	Kg/h		3,5	5
Motor power (IE2)	kW (3~)		5,5	9
Nominal r.p.m.	n/min		1400	1700
Noise level (UNI EN ISO 2151) (K 3dB)	dB(A)		70	74
Weight	kg (3~)		170	180
Type of oil	cod. DVP		SYN HP 110	
Oil quantity	Min÷Max dm <sup>3</sup>		4 ÷ 5	
Pump Intake / Outlet	"G		2 / 2	
Continuous-duty working range (Abs.)	mbar - hPa		400 ÷ 0,3	
Operating temperature (room temp. 20°C)	70 ÷ 75	75 ÷ 80	75 ÷ 80	80 ÷ 85
Required room temp. for place of installation	°C		12 ÷ 40	
Ambient temperature for storage/transport	°C		-20 ÷ 50	
MAX humidity / altitude			80% / 1000m s.l.m. <sup>(1)</sup>	

(1) Please contact the Manufacturer if environmental conditions are different from those prescribed.



## 3.4.7 Model: LC 205HV - LC 305HV

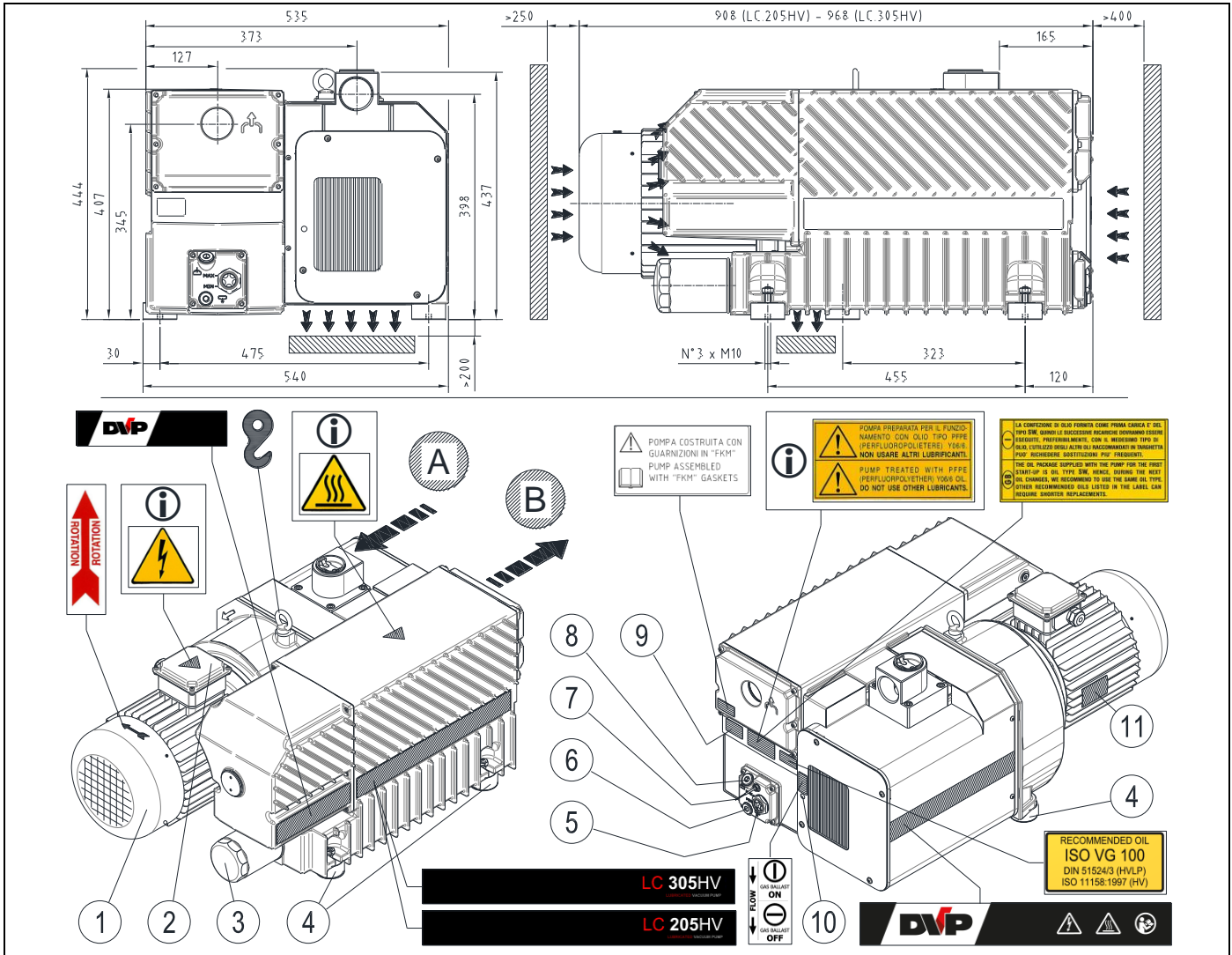

<b>A</b>	Intake
<b>B</b>	Air outlet
<b>1</b>	Motor fan guard
<b>2</b>	Terminal board
<b>3</b>	Oil filter

<b>4</b>	Attachment point
<b>5</b>	Oil sight glass
<b>6</b>	Oil drain plug
<b>7</b>	Level switch (optional)
<b>8</b>	Oil filler plug

<b>9</b>	Information plate
<b>10</b>	Gas Ballast ON/OFF
<b>11</b>	Motor rating plate
<b>ⓘ</b>	Only present on special versions

### TECHNICAL SPECIFICATIONS

		LC 205HV		LC 305HV	
		50 Hz	60 Hz	50 Hz	60 Hz
Inlet capacity	m <sup>3</sup> /h	205	245	305	365
Final pressure (Abs.)	mbar - hPa	0,1 <sup>(2)</sup>			
Max inlet pressure for water vapour	mbar - hPa	10 <sup>(3)</sup>		12 <sup>(3)</sup>	
Max water vapour pumping rate	Kg/h	2,1 <sup>(3)</sup>		3,5 <sup>(3)</sup>	
Motor power (IE2)	kW (3~)	5,5	6,6	7,5	9
Nominal r.p.m.	n/min	1400	1700	1400	1700
Noise level (UNI EN ISO 2151) (K 3dB)	dB(A)	69	71	71	73
Weight	kg (3~)	170		180	
Type of oil	cod. DVP	SW100			
Oil quantity	Min÷Max dm <sup>3</sup>	4 ÷ 5			
Pump Intake / Outlet	"G	2 / 2			
Continuous-duty working range (Abs.)	mbar - hPa	400 ÷ 0,1			
Operating temperature (room temp. 20°C)	°C	65 ÷ 70	70 ÷ 75	70 ÷ 75	75 ÷ 80
Required room temp. for place of installation	°C	12 ÷ 40			
Ambient temperature for storage/transport	°C	-20 ÷ 50			
MAX humidity / altitude		80% / 1000m s.l.m. <sup>(1)</sup>			

(1) Please contact the Manufacturer if environmental conditions are different from those prescribed.

(2) With ballast closed.

(3) With open Gas Ballast.

## 3.4.8 Model: RC 50M

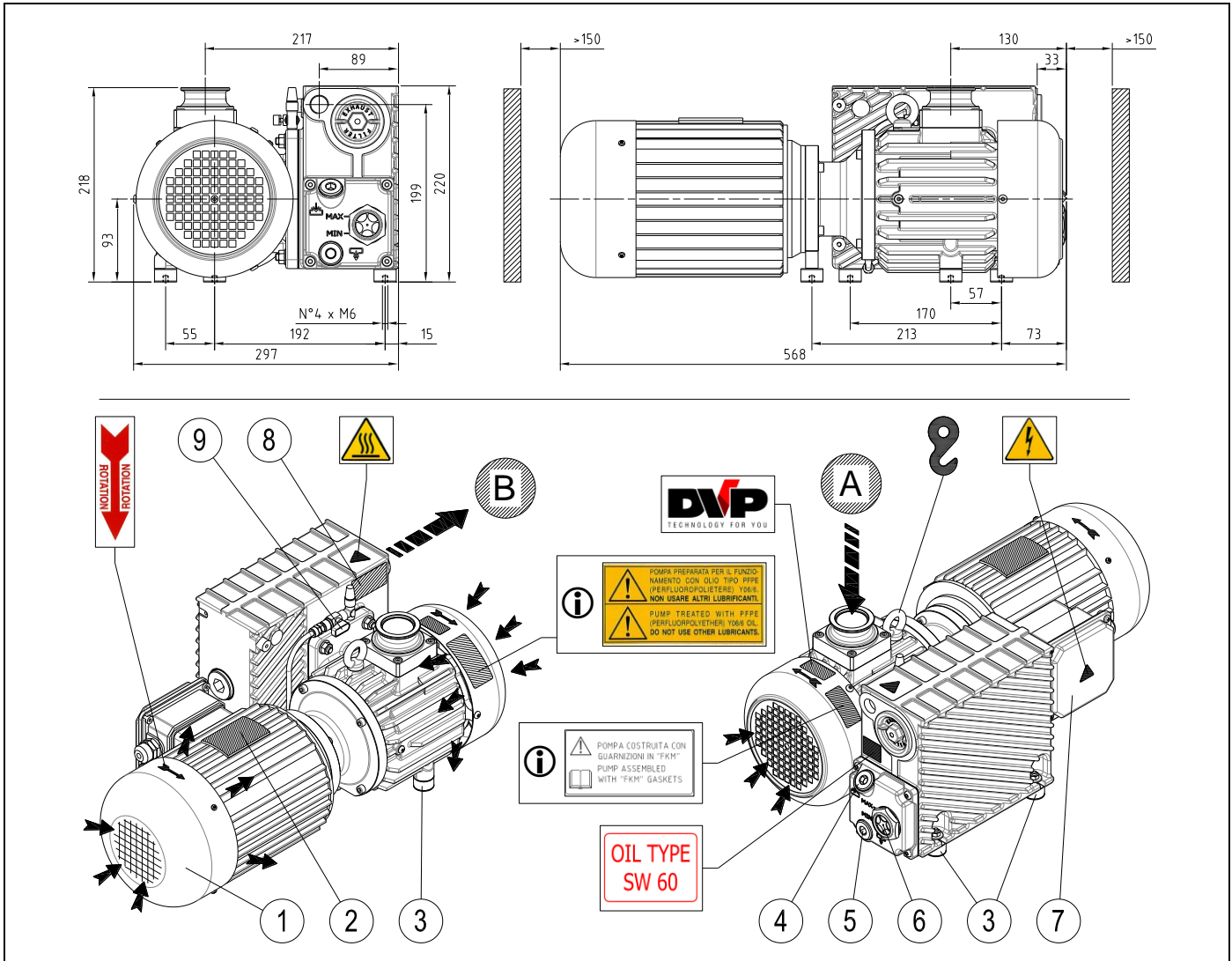

<b>A</b>	Intake
<b>B</b>	Air outlet
<b>1</b>	Motor fan guard
<b>2</b>	Motor rating plate

<b>3</b>	Attachment point
<b>4</b>	Oil filler plug
<b>5</b>	Oil drain plug
<b>6</b>	Oil sight glass

<b>7</b>	Terminal board
<b>8</b>	Information plate
<b>9</b>	Gas Ballast ON/OFF
<b>i</b>	Only present on special versions

### TECHNICAL SPECIFICATIONS

		RC 50M	
		50 Hz	60 Hz
Inlet capacity	m <sup>3</sup> /h	60	60
Final pressure (Abs.)	mbar - hPa	0,05 <sup>(2)</sup> / 0,2 <sup>(3)</sup>	
Max inlet pressure for water vapour	mbar - hPa	8 <sup>(3)</sup>	10 <sup>(3)</sup>
Max water vapour pumping rate	Kg/h	0,4 <sup>(3)</sup>	0,5 <sup>(3)</sup>
Motor power (IE2)	kW (3~)	1,1	1,35
Nominal r.p.m.	n/min	1400	1700
Noise level (UNI EN ISO 2151) (K 3dB)	dB(A)	63	66
Weight	kg (3~)	170	180
Type of oil	cod. DVP	SW60	
Oil quantity	Min÷Max dm <sup>3</sup>	0,7 ÷ 1	
Pump Intake / Outlet		DN40 / 1/2" G	
Continuous-duty working range (Abs.)	mbar - hPa	100 ÷ 0,05	
Operating temperature (room temp. 20°C)	°C	55 ÷ 60	60 ÷ 65
Required room temp. for place of installation	°C	12 ÷ 40	
Ambient temperature for storage/transport	°C	-20 ÷ 50	
MAX humidity / altitude		80% / 1000m s.l.m. <sup>(1)</sup>	

(1) Please contact the Manufacturer if environmental conditions are different from those prescribed.

(2) With ballast closed.

(3) With open Gas Ballast.



### 3.5 NOISE EMISSION

This pump has been designed and constructed to reduce noise at its source.

The sound pressure levels contained in the table of technical specifications were measured at maximum vacuum and outlet conveyed according to UNI EN 2151.

## 4 INSTALLATION

### 4.1 RECEIPT AND CONTENT VERIFICATION

Upon receipt of the pump, verify that the packaging is intact. If everything is intact, unpack the contents and check the pump. If packaging shows signs of damage due to transport or storage conditions, immediately notify the shipping agent and the manufacturer.

It is always necessary to check that the material received corresponds to its accompanying document.

Packages should be opened taking all precautions to avoid harm to people and the contents thereof.

### 4.2 PACKAGING

Depending on the size and based on the mode of transport, the pump is packaged in the following ways:

- single box with infill material;
- on wooden pallets with cardboard covers;
- in single boxes positioned on pallets with protective film.

The pallet wood can be reused or recycled in accordance with applicable laws in the country of pump installation. Other materials such as cardboard, plastic or protective film must be disposed of in accordance with local regulations.

Do not burn or disperse package components in the environment.

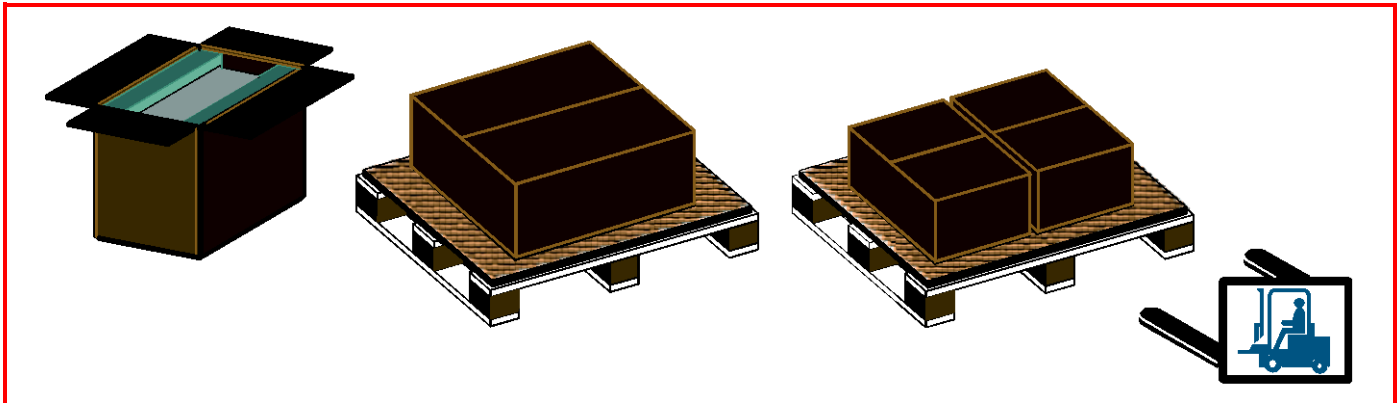

### 4.3 TRANSPORT AND HANDLING



#### HAZARD

All transportation, lifting and handling operation must be performed by qualified and experienced personnel.

The pump can be lifted and moved with forklifts or with lifting equipment (ropes, hooks, etc.) that are appropriate to the weight indicated in the table of technical data and on the identification plate. Manual handling and transportation are permitted only in accordance with local regulations.



#### WARNING

Prepare the pump as detailed in the next chapter and empty the oil tank (see "Changing the oil") for transport.

### 4.4 STORAGE

Drain the pump of oil inside and close the intake and outlet with the appropriate protections. The pumps are to be stored in their packaging and stored in covered, dry, protected places that are not exposed to bright sunlight, with temperatures in the range indicated in the table of technical specifications.

In case of long periods of stop inside the warehouse or out of production with storage, the location should meet the specifications described in Chapter 3 (Pump description). In order to keep rubber parts and lip seals efficient and properly working, we recommend to operate the pump for at least 30 minutes every 6 months with the intake closed, following the instructions and provisions described in this manual, paying particular attention to those in Chapter 5 (Use instructions). The non-observance of the provisions could cause the rubber parts to degrade leading to oil leakages during operation.

### 4.5 ENVIRONMENTAL CONDITIONS

The pump must be installed and used in a covered and adequately lit location. The installation area must meet all requirements of height, air circulation and meet the requirements imposed by existing legislation.

#### Temperature, Humidity and altitude

The corresponding limit values are shown in the table of the technical specifications (chapter 3.3). Please contact the Manufacturer if environmental conditions are different from those prescribed.

#### Lighting

All areas must be illuminated evenly and sufficiently to ensure all operations included in this manual and must be without shadows, reflections, glare or eyestrain.

### 4.6 PUMP INSTALLATION

To ensure perfect pump operation, house and place it according to the following conditions:

- Allow sufficient space on the perimeter sides of the pump and make sure to keep the motor ventilation side free.
- Make sure the free space adjacent to the pump allows easy access to components for inspection or maintenance and also allows access for suitable lifting equipment.
- The pump is equipped with mounting points. It is necessary to ensure it locks onto a perfectly horizontal plane in order to avoid tilting in case of transportation by the system user.
- Some models are already equipped with rubber vibration dampers installed at pump attachment points. Whenever the model has not been equipped, ensure installation of such equipment so as not to transmit vibration to the pump.
- Ensure there is ventilation in the room, or inside the machine housing the pump and prevent air coming in from the outlet or cooling fans, which could cause discomfort to personnel.



#### WARNING

Do not install the pump in any area with dust or other materials that could clog or rapidly cover cooling surfaces.

### 4.7 MOTOR INSTALLATION

It is possible to install any type of electric or hydraulic motor (NOT for RC 50M) that has the features described in the table of technical data, with flange and shaft corresponding to:

M100/4, M112/4 - B5 size as per standard IEC-72 for LC 106, LC 106 Kzero, LC 151 and LC 151 Kzero;

M132/4 - B5 size as per standard IEC-72 for LC 205, LC 305, LC 205 Kzero, LC 305 Kzero, LC 205HV and LC 305HV.



#### WARNING

Install fan/coupling assembly on the motor following these instructions:

- Remove the fixing clamp from the connecting joint on the pump;
- Fit the assembly on the motor shaft up to reaching the stated measure (on the LC 106, LC 106 Kzero, LC 151 and LC 151 Kzero models fit the motor drive coupling up to the second shoulder);
- Tighten screw "A" to firmly fix the assembly to the shaft.

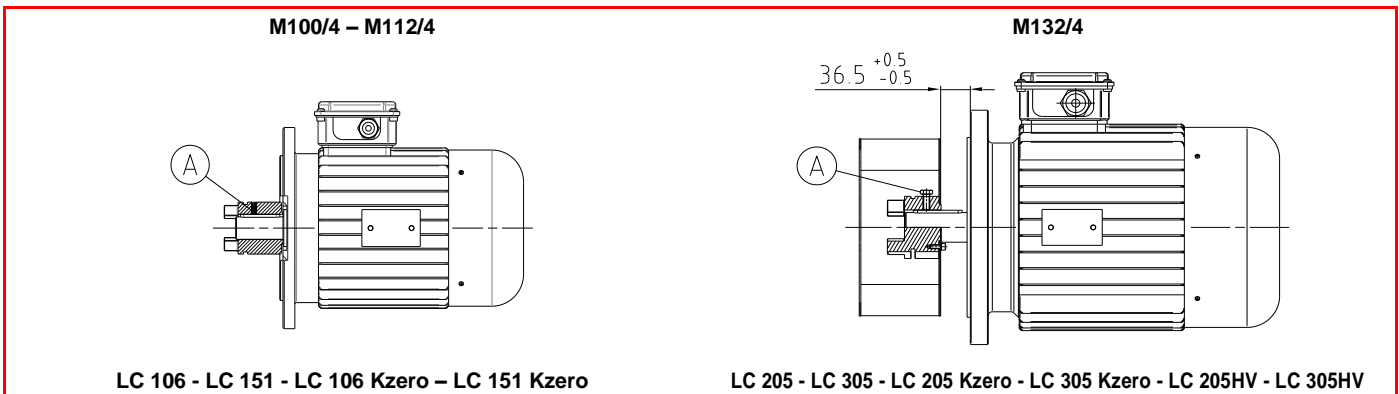

LC 106 - LC 151 - LC 106 Kzero - LC 151 Kzero

LC 205 - LC 305 - LC 205 Kzero - LC 305 Kzero - LC 205HV - LC 305HV

### 4.8 USER SYSTEM

Make sure that no harmful substances contaminate the user system during installation.

**If you wish the system to maintain vacuum even when pump is stopped, install a cutoff valve between pump and system.**

Make sure that no vibrations or stresses are transmitted to the pump connection.

## 4.9 CONNECTION



### HAZARD

Pump connections should be performed by skilled and trained personnel only.

### 4.9.1 INTAKE AND OUTLET CONNECTIONS

User system connections (both intake and outlet) must be performed with pipes with a diameter equal to or greater than the pump suction inlet. The weight of pipes or any expansions must not burden the pump.

It is advisable to make the final connection to the pump using flexible pipe or fittings. It is important to tighten all pipes and couplings. Very long pipes or pipes with a diameter that is too small diminish pump performance.



### HAZARD

Make sure that discharged gases are let out of the workplace.



### WARNING

Always install an intake filter, especially if the pump is to work with air that might contain foreign matters.

Pump outlet gases must be treated in such a way that they do not contaminate the working environment and the surrounding atmosphere. If condensable vapours are pumped in, the discharge hose should be routed downwards and have no bends to prevent the condensate produced in the discharge line from building up or flowing back into the pump.

Never use friction hoses with hose diameters smaller than the intake diameter. Avoid exceeding hose lengths, tight bends or bends spaced too closely together.



### WARNING

Do not insert outlet fitting pipes or devices that block or impede the disposal of outlet gases (max overpressure exhaust 0.3 bar).

### 4.9.2 WIRING



### WARNING

Check that network voltage and frequency correspond to values contained on the motor rating plate.

The connection cable must be adequate for the power absorbed by the pump (absorption values are shown on the pump motor rating plate) taking into account the environmental conditions of operation.



### HAZARD

Always ground the pump.

Always install a security system between the pump and the electric power supply. Pump absorption values are shown on the motor rating plate.

The pump is normally supplied without an electrical cable and switch. For electrical connection, see the diagram contained within the terminal board or on the motor rating plate.



### WARNING

Check that the direction of rotation is correct before starting the pump for the first time or after changing the electrical connections.

The correct direction of rotation is indicated by the arrow on the pump (see ch. 3.3). Pump operation with a rotation direction that is opposite to that indicated can severely damage the pump itself.

### 4.9.3 ELECTRICAL OIL LEVEL GAUGE (OPTIONAL)

If installed, the electrical oil level gauge signals when level inside the tank descends below minimum level.

Oil level gauge characteristics are as follows:

- VOLTAGE SWITCHING: Max 250Vdc & Vac
- CURRENT SWITCHING: Max 0.5 Adc / Max 0.7 Aac
- CONTACT RATING: Max 50VA



### WARNING

The signal from this device may NOT be used to directly drive the motor.

## 5 OPERATING INSTRUCTIONS

### 5.1 OPERATION

#### Checks to be performed before start-up:

- The pump is supplied without any oil in it. Use the supplied oil or an oil lubricant indicated on the identification plate of this pump (see ch. 3.3) or, alternatively, an alternative lubricant of another brand but with similar characteristics;
- Make sure the pump outlet is not obstructed by fittings.



#### WARNING

A quantity of oil that exceeds the necessary quantity may cause the clogging of oil separators and damage to the pump or to the electric motor.  
Operation without lubricant causes serious damage to the pump.

#### 5.1.1 FILLING THE OIL TANK



#### WARNING

When filling the oil tank never exceed allowed maximum level.

- Undo the oil filler plug;
- Pour oil in the tank up to mid-range of the oil sight glass;
- Close the filler plug;
- Remove all oil spills from the pump and/or floor.

#### 5.1.2 START-UP



#### HAZARD

The pump may reach high temperatures when operating.



#### WARNING

The models LC 40, LC 60, LC 106, LC 151, LC 205, LC 305, LC 205HV, LC 305HV and RC 50M are provided with a special “open” valve to exclude the Gas Ballast.

After start-up, the pump may run slower than the regular rpm if room temperature is lower than allowed as seen on the technical data table. It may also run lower if the oil is contaminated or the supply voltage is lower than the required voltage as indicated on the motor rating plate.

If nominal rpm is not reached within a few seconds, the thermal switch fitted to protect the pump must trip (installation required in paragraph "Wiring").



#### WARNING

If water vapour should be taken in, take the pump to a steady temperature by leaving it to run for approximately 30 minutes with the suction inlet closed and the system containing the water vapour isolated before starting the work cycle.



#### WARNING

Make sure the pump is working at the allowed pressure value and do not leave the pump running for a long time with the suction inlet completely open.



#### WARNING

It is advisable not to start the pump more than 12 times per hour to avoid excessive energy consumption and damage to the pump, especially for models LC 106, LC 106 Kzero, LC 151, LC 151 Kzero, LC 205, LC 305, LC 205 Kzero, LC 305 Kzero, LC 205HV, LC 305HV, RC 50M.



#### HAZARD

Full r.p.m. pump operation must be without vibration or unusual noise. If these are present, stop the pump immediately, search for the cause and eliminate it.

#### 5.1.3 STOP

The pump must be stopped by cutting off the power supply.

If the pump is to be powered off, let it run with closed intake for about 30 minutes first.

This will eliminate any moisture inside the intake chamber and avoid rotor oxidation.

In the case of long machine downtime, completely empty the pump to avoid hazards of frost during cold weather or corrosion due to possible chemical alteration of the stagnant liquid in the pump.

### 5.1.4 PUMPING WATER VAPOUR

While operating in the presence of water vapour, the pump takes in a mixture of air and water which enters the pump and therefore also the oil tank.

The aspirated water vapour is expelled by the heat generated by the pump during operation together with the presence of the gas ballast device.

This latter lets air enter the chamber, facilitating the elimination of the aspirated water vapour and thus avoiding condensation in the oil.

The gas ballast device is equipped with a cut-off valve (“open”), this latter is not present in models LC 25, LC 106 Kzero, LC 151 Kzero, LC 205 Kzero and LC 305 Kzero where the gas ballast is always active.

**Therefore, if water vapour is present, it is essential that before the work cycle is started the pump must reach its operating temperature – this is achieved by running it for about 30 minutes with the suction inlet closed, isolating it from the user system and setting the cut-off valve open.**

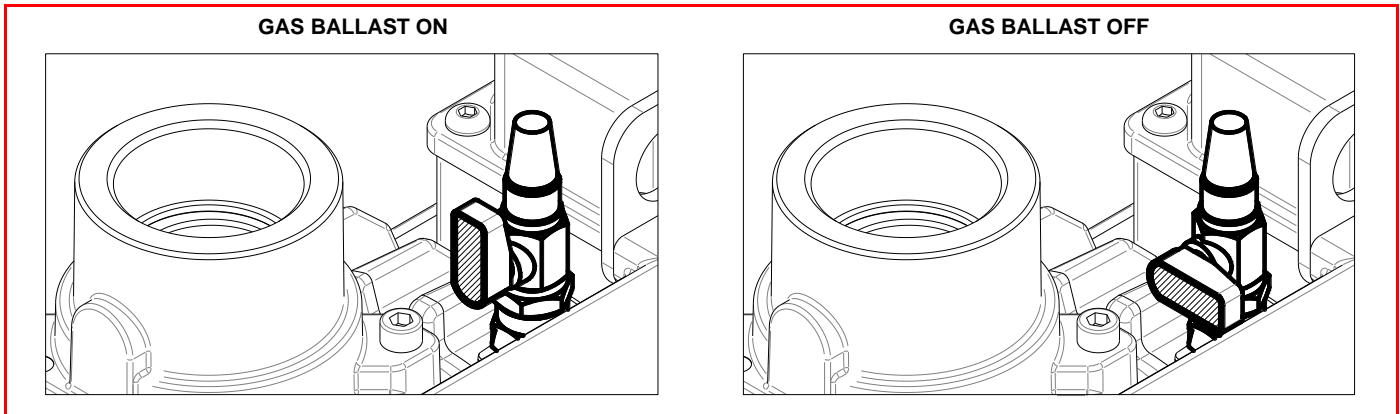

## 6 MAINTENANCE

### 6.1 GENERAL WARNINGS

For good maintenance:

- Immediately verify the causes of any malfunctions (excessive noise, overheating, etc.);
- Pay particular attention to safety devices;
- Make use of all documentation provided by the manufacturer (instruction manuals, wiring diagrams, etc.);
- Use only appropriate tools and original spare parts.

In the event of a failure to understand the information or procedures contained in this chapter, contact D.V.P. Vacuum Technology s.p.a. for clarification before proceeding.

**HAZARD**



**Do not perform any type of operation, modification and/or repair of any kind, except for those listed in this manual.**



**Only trained or authorised personnel have the necessary expertise to perform tasks with the technique appropriate for intervention.**

**HAZARD**



**All maintenance operations must be carried out with the pump disconnected from any power sources. Do not operate the pump until it has reached a temperature that is not dangerous for the operator.**

**HAZARD**



**If pump maintenance has been performed in a manner inconsistent with instructions, with non-original spare parts or otherwise so as to impair its integrity or modify its characteristics, D.V.P. Vacuum Technology s.p.a. will be released from any liability relating to the safety of persons and malfunction of the pump.**

## 6.2 MAINTENANCE TABLE

The following table shows all required periodic operations to maintain pump efficiency.

OPERATION TYPE	FREQUENCY	OPERATOR QUALIFICATION
Check the oil level	24 h	
Change oil	500 h	
Clean radiator, motor fan guard and clean pump	1000 h	
Change the oil filter (only where present)	1000 h	
Change the air exhaust filter	2000 h	
Change vanes	10000 h	

Shorter maintenance intervals may be required according to operating conditions (high temperature of intake gases, intake gases containing condensable vapours, etc.).

### 6.2.1 CHECK OIL LEVEL

Check that oil level is at mid-range of the oil sight glass. If not, see instructions in the following paragraph. Check oil conditions. When dark or cloudy, oil has been contaminated by intake substances and must be changed.

### 6.2.2 CHANGE OIL

- Change oil as follows:
- Let the pump run with closed suction intake for about 10 minutes first so oil will become thinner;
- Stop the pump and disconnect it from the mains;
- Undo the oil filler plug;
- Get a container large enough to hold all oil and open the oil drain plug;
- Drain out all oil;
- Close drain plug and fill in fresh oil through the filler plug up to mid-range on the oil sight glass;
- Close the oil filler plug;
- Remove all oil spills from the pump and/or floor.
- Connect to mains again and verify correct rotation direction of the pump (see chapt. 3.3.);
- Let the pump run with closed intake for a few minutes and then, if necessary, top up oil if necessary.



**HAZARD**

**Wear appropriate personal protection equipment to perform said operations.**



**HAZARD**

**Comply with local regulations regarding the collection and disposal of used or polluted oil.**

### 6.2.3 CLEAN RADIATOR, MOTOR FAN GUARD AND CLEAN THE PUMP

Radiator, motor fan guard and the pump should be cleaned to remove any dust deposits.

This can be done using compressed air and a dry cloth.

**Be careful not to damage the components of the oil cooling radiator (where present) by approaching the jet of compressed air or by exerting excessive pressure with the cloth.**

Do not use fluids or substances other than those indicated.



**HAZARD**

**Wear appropriate personal protection equipment to perform said operations.**

### 6.2.4 CHANGE THE AIR EXHAUST FILTER

The air exhaust filter must be changed when it is damaged or clogged or when it has reached its authorised life as per Chap 6.2.

Only use original DVP filters from the Filters Spare Parts (see Chap.6.3). Use of parts other than those approved by DVP can cause deterioration of the pump.

The signs showing a filter is clogged or damaged are increased exhaust fumes, increased noise-level and consumption of electricity (see Chap.9 points C and E).



It is possible to measure the level of clogging of the oil separator filter by looking at the  $\Delta P$  of the filter with the pump warm. On pumps equipped with a measuring point for  $\Delta P$  it is possible to check the filter by attaching a gauge or the accessory code SIF.2 to it. For pumps without this facility a measuring instrument can be connected in place of the oil filler cap.

For a pump operating and with hot oil the filter is clogged if the value of  $\Delta P$  is greater than 0.7bar (at sea level). If this is the case the oil separator filter must be replaced.

### 6.2.5 CHANGE THE OIL FILTER (ONLY WHERE PRESENT)

The oil filter must be replaced in accordance with the instructions in the table in Chapter 6.2.

Only use the approved filters from the Filters Spare Parts (see Chapter 6.3), this is equipped with a by-pass valve regulated to 0.5bar. Use of non-original parts may damage the pump.

The oil must be drained from the pump before replacing the filter (see Chap.6.2.2), then unscrew the used filter using a spanner or socket wrench.

The disposal of the used filter must respect the local regulations for disposal of such materials.

Before installing the new filter lubricate the gasket with oil, clean the seat of the gasket and then tighten the new filter in place by hand. Don't use a spanner or wrench to tighten the filter in place.

Once this is completed follow the instructions to refill the oil in Chapter 6.2.2.

### 6.2.6 CHANGE VANES

The instructions for replacing vanes are available upon request.

## 6.3 SPARE PARTS

Use **Original Spare Parts** to replace pump parts.

When purchasing spare parts, always quote the serial number and model of the pump (these can be found on the identification plate) as well as the spare part purchase number.

DESCRIPTION	LC 25	LC 40	LC 60	LC 106	LC 106 Kzero	LC 151	LC 151 Kzero
Vanes spare parts	KP000003	KP000002		KP000004		KP000005	
Filters spare parts	KF000010	KF000008		KF000004		KF000006	
Gaskets spare parts	KG000011	KG000009		KG000004		KG000005	
Valves spare parts	KV000005	KV000004		KV000001	KV000034	KV000001	KV000034
Oil 0,25 dm <sup>3</sup>	-----						
Oil 0,5 dm <sup>3</sup>	-----						
Oil 1 dm <sup>3</sup>	8812100 (BV68) 8832100 (SW60)		-----				
Oil 2 dm <sup>3</sup>	8812200 (BV68) 8832200 (SW60)		-----				
Oil 3 dm <sup>3</sup>	-----				8888300 (SYN HP 110)	-----	8888300 (SYN HP 110)
Oil 5 dm <sup>3</sup>	8812500 (BV68) 8832500 (SW60)		8813500 (BV100) 8833500 (SW100)		-----	8813500 (BV100) 8833500 (SW100)	-----

DESCRIPTION	LC 205	LC 305	LC 205 Kzero	LC 305 Kzero	LC 205HV	LC 305HV	RC 50M
Vanes spare parts	KP000001						KP000019
Filters spare parts	KF000001						KF000017
Gaskets spare parts	KG000001				KG000003		KG000024
Valves spare parts	KV000002		KV000033		KV000003		KV000012
Oil 0,25 dm <sup>3</sup>	-----						8832025 (SW60)
Oil 0,5 dm <sup>3</sup>	-----						8832050 (SW60)
Oil 1 dm <sup>3</sup>	-----						8832100 (SW60)
Oil 2 dm <sup>3</sup>	-----						
Oil 3 dm <sup>3</sup>	-----						
Oil 5 dm <sup>3</sup>	8813500 (BV100) 8833500 (SW100)		8888500 (SYN HP 110)		8833500 (SW100)		-----

D.V.P. Vacuum Technology s.p.a. disclaims all responsibility for any deterioration of pump performance or for damages caused due to use of non-original spare parts.

## 7 HOW TO RETURN THE PUMP

The product may only be returned after prior agreement with the supplier, who will provide the authorisation number that must accompany the material delivered and should be duly complete in its entirety.

## 8 DISMANTLING



Demolition of the pump must be performed by authorised technicians.

Metal parts can be disposed of as scrap metal.

All materials deriving from demolition must be disposed of according to regulations in the country where the pump will be demolished.

### HAZARD



Disposal operations involve risks of cutting, shavings protection, entanglement, contact with moving parts and contact with chemicals. Operators should use the appropriate personal protective equipment.



*Note for devices under EEE management, with the label shown on the side as an example)*

### INFORMATION FOR USERS OF PROFESSIONAL EQUIPMENT

**"Implementation of Directive 2012/19/EU on waste electrical and electronic equipment (WEEE)".**

**Information available at [www.dvppumps.com](http://www.dvppumps.com) in the WEEE section.**

## 9 TROUBLESHOOTING

DAMAGE	CAUSE	REMEDY
<b>(A)</b> The pump does not run	No voltage	Provide power supply
	Thermal switch has tripped	Identify reason and activate switch
	Room temperature is too low	Restore room temperature to allowed range
	Motor winding damaged	Contact Service Department
<b>(B)</b> The pump cannot reach stated vacuum	Low oil in tank	Top up oil
	Oil contaminated	Change oil
	Discharge clogged	Check couplings at outlet
<b>(C)</b> Pump is noisy	Air exhaust filter clogged	Change the air exhaust filter
	Bearings damaged	Contact Service Department
	Motor coupling damaged (where present)	Contact Service Department
	Vanes worn out	Contact Service Department
<b>(D)</b> Pump runs hot	Oil is not the suitable type	Change oil
	Poor room ventilation	Install an auxiliary ventilator
	Motor fan broken	Contact Service Department
	Wrong power supply to motor	Check power supply
	Discharge clogged	Check couplings at outlet
<b>(E)</b> High oil consumption	High working pressure (close to atmospheric pressure)	Check oil level frequently
	Pump runs hot	See point "D"
	Air exhaust filter clogged	Change the air exhaust filter
<b>(F)</b> Pump does not maintain vacuum after power-off	Check valve damage (if fitted)	Contact Service Department
<b>(G)</b> Pump leaks oil	Tank screws or plugs loosened	Tighten screws or plugs
	Tank gaskets damaged	Contact Service Department
	Oil sight glass not tightened	Tighten the oil sight glass

## GENERAL CONDITIONS OF SALE

D.V.P. Vacuum Technology s.p.a. supplies products exclusively for professional clientele, hence, excluding consumers.

## PRODUCT WARRANTY TERMS AND CONDITIONS

D.V.P. Vacuum Technology s.p.a. guarantees that the product is free from material or manufacturing defects for a period of 24 months of normal use from the shipping date. This period is of 6 months of normal use for products subject to repair not under warranty.

Normal use means an operating cycle of 8 hours per day for a maximum of 5000 operating hours in the 24 months covered by the warranty.

Warranty means the free replacement or repair at its own assistance network of any components of the product that are found to be faulty from the start due to manufacturing defects.

In the event of repair, D.V.P. Vacuum Technology s.p.a. guarantees, exclusively to its own customer, the identical spare parts for 24 months from the shipping date; once this period has passed, the pieces may no longer be available on the market, therefore the repairs, even under warranty, may require the payment of a difference between the product purchased and that installed during the repair. This price will be indicated to the customer before the repair is carried out, for acknowledgement and acceptance.

D.V.P. Vacuum Technology s.p.a. will do everything reasonable within its power to respect the assistance times and *standard* response (20 working days), which may vary according to the distance and accessibility of the place where the product is located and the availability of the components.

D.V.P. Vacuum Technology s.p.a. will not be held responsible for any direct or indirect losses caused by its failure to respect the assistance times and will not have any responsibility or contractual or civil obligation for product faults or for failure to repair the faults in a reasonable period of time.

In the event of irreparable faults, the product will be replaced. The replacement will cause the original warranty to be extended to the new product, until its expiry date.

The warranty does not cover any parts that appear to be faulty due to negligence and/or carelessness during use (failure to observe the equipment operating instructions, lack of maintenance), incorrect installation and/or maintenance, maintenance carried out by unauthorized staff, damage due to transport, or circumstances which, in any case, cannot be attributed to manufacturing faults on the equipment.

The warranty also excludes all components of the product that have been modified or repaired without prior written authorisation from D.V.P. Vacuum Technology s.p.a.

The warranty also excludes any faults deriving from improper use, normal wear, galvanic and electrostatic currents, chemical corrosion, tampering, replacement or elimination of the registration plate.

The warranty does not cover, in any case, faults generated by external causes, such as accidents and fortuitous events.

D.V.P. Vacuum Technology s.p.a. declines all responsibility to anyone for any damage and, consequence, of any kind and/or reason, that may derive from the use of the product, as well as for any faults that it may present.

By way of non-limiting example, it declines all responsibility:

- for any damage that could, directly or indirectly, be caused to people, objects and animals, due to failure to observe all the instructions indicated in the relevant use and maintenance manual, especially the indications on the installation, use and maintenance of the equipment;
- for any damage and/or loss caused by faults of deficiencies of products repaired by D.V.P. Vacuum Technology s.p.a.;
- for any indirect or consequential damage such as, by way of non-limiting example, loss of business, profits, salaries, payments etc.;
- losses that could have been avoided by the customer by following the advice and instructions from D.V.P. Vacuum Technology s.p.a..

In any case, the customer waives the right to claim any right and/or demand as well as raising any objection or promoting any action, inherent to the use of the product.

The warranty is not extended to consumable parts, or faults deriving from: filtering cartridges, blades, membranes or sealing rings, as well as third party products that are part of the final product.

The transport, removal and subsequent re-installation costs of the repaired or replaced product are, however, to be entirely borne by the customer.

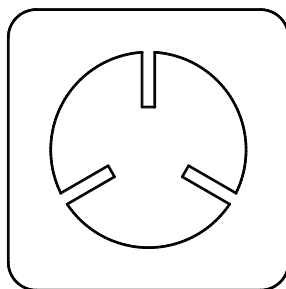

***D.V.P. Vacuum Technology s.p.a.***

Via Rubizzano, 627

40018 San Pietro in Casale (BO) – Italy

Ph +3905118897101

Fx +3905118897170

[www.dvppumps.com](http://www.dvppumps.com)

Cod. 8702035 – 04/09/2023 – R.13 – ( EN )